

The Compact, powerfull Hydraulic core drilling rig

- Powerfull Hydraulic drill head
- 3 Mtr feed stroke, 3 Mtr Rod pull
- Can be shifted on Bolero/pickup — very fast
- Hydraulic foot clamp



Model No.: KDR - 100

<b>Application</b>	Soil tech, Limestone & Mineral Exploration
<b>Capacity</b>	<b>100 Mtr</b> with NQ Rod ( Bar Diameter 3")
	<b>75 Mtr</b> with HQ Rod ( Bar Diameter 4")
<b>Drilling Method</b>	Rotary, Core,
<b>Prime Mover*</b>	Kirloskar HA494 developing <b>73 HP</b> power diesel engine
<b>Mounting Platform Structure</b>	Trailer mounted
<b>Mast Assembly</b>	Heavy duty Beam type mast
	Mast. length: <b>5.0 Mtr</b>
	Rotary Head Travel: <b>3 Mtr</b>
	Spindle Bore : <b>NQ Size</b>
	Pullup Force : <b>1500 Kgs</b>
	Pull down Force : <b>1000 Kgs</b>
<b>Mast Raising Cylinder</b>	The mast is raised and lowered by mechanical cylinder. Hoisting of drill rod shall be done with Drill head adaptor 3 Mtr.
<b>Feed System</b>	Well proven hydraulic feed system through Cylinder
	Feed Stroke : <b>3 Mtr</b>
	Rod Pull : <b>3 Mtr</b>
	Pull Up Speed: <b>20 m/min</b>
	Pull Down Speed: <b>20 m/min</b>
<b>Rotary Head Assembly (Top Head Drive)</b>	Kores well proven Drill head, fabricated steel body with gear reduction and oil bath lubrication type gearbox along and spindle with NW size, driven by hydraulic motor

**Model No.: KDR - 100**

Hydraulic Power	2 x Fixed displacement pump for Feed & Rotation
Drill head Speed & Torque	Drill head speed :0-600 RPM
	Drill head Torque :0-1500 lbf
Levelling Jacks	4 x Mechanical screw type levelling jacks are provided each corner for quick setting and levelling of the drill rig. (Optional Hydraulic jacks with extra charges)
Wireline Winch	Drill is provided Hydraulic operated wireline winch Length :- 200 Mtr X 5 mm rope
Foot Clamp	Drill is equipped with Hydraulic operated foot clamp to hold all casing & rods up to HQ size
Mud Pump	Heavy duty Triplex reciprocating mud pump / Centrifugal pump, Flow Capacity: 120 LPM, Pressure: 700 PSI, With Ceramic liners, operated by hydraulic motor.
Control Panel	Drill is provided with centralised control panel with all controls e.g. Spindle RPM, Mud pump, Feed, Engine controls, all pressure gauges to have full control of rig.

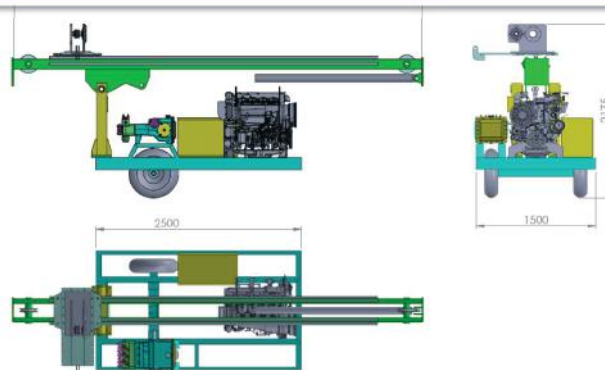

# Model No.: KDR — 100

For details — Email: [info@drilltechinternational.com](mailto:info@drilltechinternational.com)

Call/WhatsApp to [+971 55 959 0464](tel:+971559590464)